

Eigentum der Firma Leibinger GmbH 79331 Teningen. Vervielfältigung, sowie jede mißbräuchliche Verwendung, insbesondere Überlassung an Dritte oder Verwendung zu anderem als dem vereinbarten Zweck, berechtigt zur Forderung von Schadenersatz.

Property of company Leibinger GmbH 79331 Teningen. Reproduction as well as any misuse particular transfer to third parties or use to other than the purpose agreed entitled to claim damages.

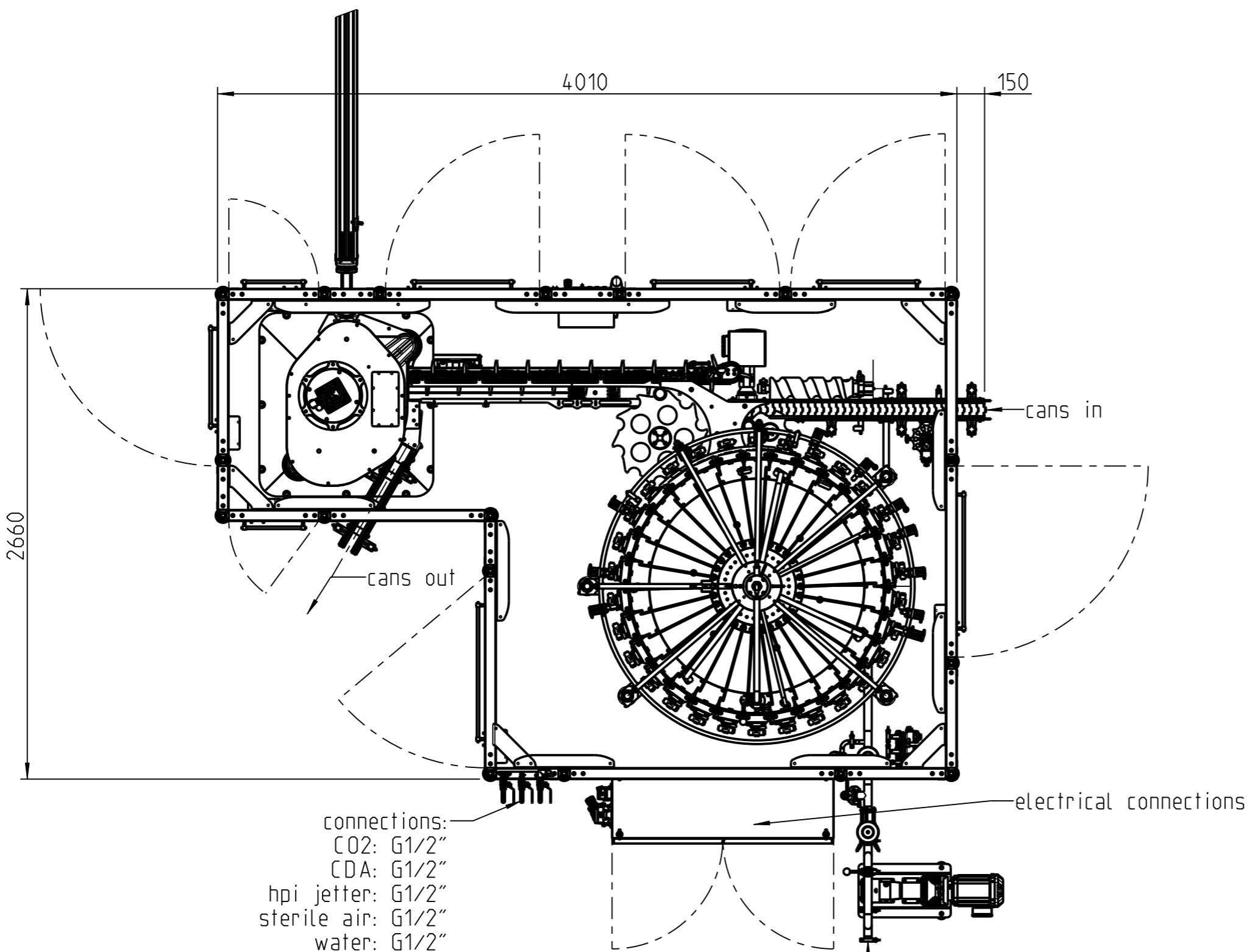

Preliminary drawing
Subject to change without notice!

max. can diameter 66mm
max. can height 168mm
top conveyor belt 1000mm
max. machine height 2800mm

for flat top chains:
880-K325
828-K325

connections:
CO2: G1/2"
CDA: G1/2"
hpi jetter: G1/2"
sterile air: G1/2"
water: G1/2"

product inlet
DN40 DIN376776-A Triclamp

>0.5-6	±0.1	Allgemeintoleranzen/ general tolerances DIN ISO 2768 mK
>6-30	±0.2	
>30-120	±0.3	
>120-315	±0.5	
>315-1000	±0.8	
>1000-2000	±1.2	
>2000-4000	±2.0	
Index	Name	Datum

Maßstab / scale: 1:25	Blatt / sheet: 1 - 1
Werkstoff / material:	
Halbzeug / raw material: -	
Benennung / title:	
Datum	Name
gez. 16.08.23	mko
gepr.	
normg.	
Zeichnungsnummer / drawing number:	
M2400-01	



Dimensional drawing
Multima 30LC + Ferrum FC03