

MULTIMA 2IN1

BOTTLE AND CAN FILLER

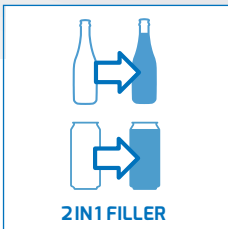
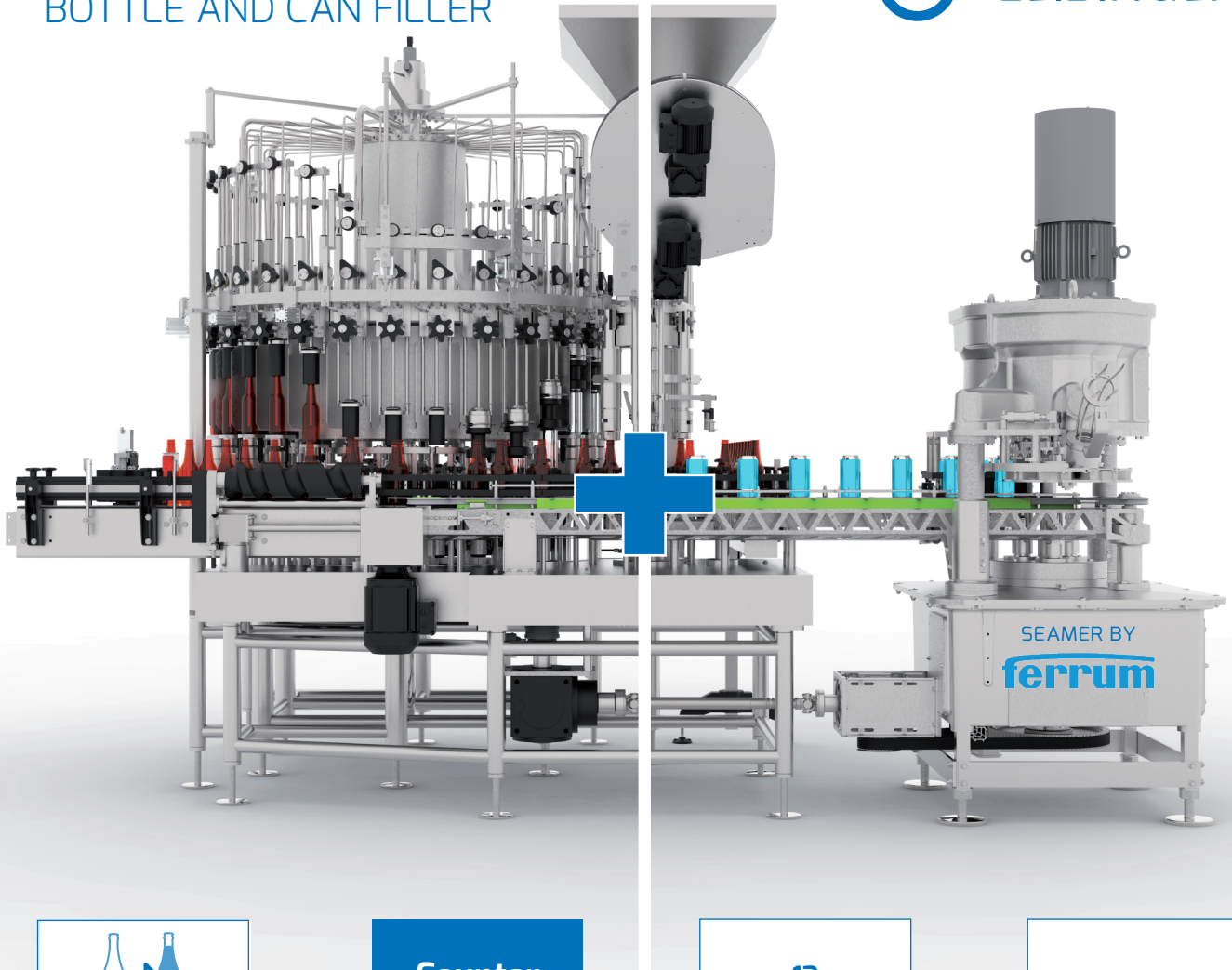

TYPE

Counter pressure
Multifunctional Filling valve

TECHNOLOGY

12
18
24
30

STATIONS

all kind of beverages

PRODUCTS

TECHNICAL DETAILS

Regulating range:	1.600 – max. 13.000* bph/cph (330 ml / 12 oz)
Conveyor belt height:	1,000 mm
Beverage pump type:	Eccentric rotor pump, stainless steel
PLC:	Siemens S7
Supply data:	400 V / 50 Hz / 3 Ph **
Drive unit:	0.75 – 3 kW SEW
Capper/Seamer:	LEIBINGER / FERRUM
Container:	Cans & Glasbottles

*product specific ** country specific

ADDITIONAL OPTIONS

- Bottle shower
- Container stop (pneumatic)
- HPI Heater (High Pressure Injection)
- Flushing device
- Additional container format set
- Spare part package
- Remote access
- PET - Bottles
- Screwcapper
- Bottlerinser
- + more options and individual features available

For the most widest range of uses

The counterpressure technology of our MULTIMA product line itself makes it particularly suitable for filling carbonated products like beer, soft drinks, sparkling wine and mineral water. The MULTIMA 2in1 model additionally expands the range of uses due to its possibility to **fill bottles and cans**. Using the integrated vacuum technology, filling with extremely low oxygen uptake is possible.

Container (Bottle / Can) and fill level adjustment

Through exchange of:

- Filling tubes
- Container guiding parts
- Centering bells

Reliability

Components are predominantly mechanical, which provides easy maintenance and a long service life.

Saving labor cost

To reduce labor costs pre-installed programs are available for:

- Automatic operation
- CIP cleaning

Materials

Mainly used materials:

- **Stainless steel** (1.4571 or 1.4404)
- **Food safe plastics** (eg. POM or PTFE)
- **Food safe elastomer** (eg. EPDM)

Safety housing

The doors consist of frameless safety glass (Makrolon). All machine areas are accessible through safety doors or removable covers.

Further characteristics

- All guiding stars secured by central friction clutch
- Mechanical lifting cylinders
- Integrated conveyor belt through the full course of the machine
- Designed for CIP cleaning
- Central lubrication system
- User friendly operating panel (HMI)
- Complies with all CE requirements at the date of shipment



Hygienic Design

For further improvement of our Hygienic Design concept we use a round tube frame instead of conventional table plate.

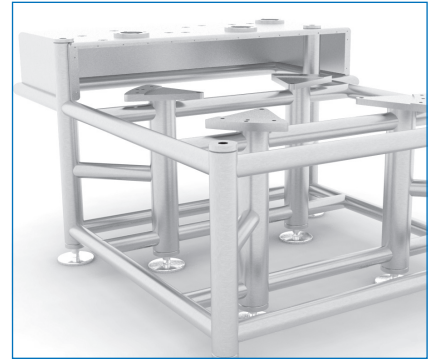

Hygienic Design: round tube frame instead of conventional table plate

We are happy to provide you with further details and all the options for your individual specifications!

+49 7641 46885-0

info@leibinger.eu

www.leibinger.eu

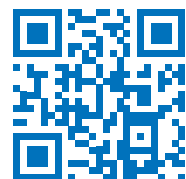

Example:
MULTIMA 2in1 - 30 head with FERRUM FCO3

